

eskabe

GAS ROOM HEATERS S21 SERIES DIRECT VENT WALL FURNACES



- Attractive styling
- Easy to use
- Enjoy heating comfort, even during an electrical power failure
- Thermostatic control models
- Safety
- Venting kit

VENTING SYSTEM
To conform with various building materials, thickness max. 10"

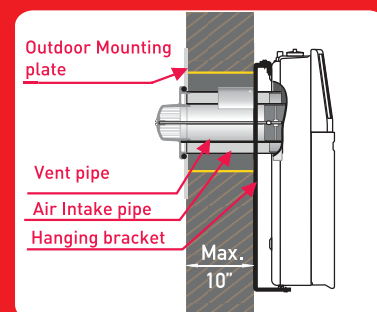

SPECIFICATIONS AND DIMENSIONS

Heater type	Model	Thermostat	Input Power	Heating Capacity up to	Width	Height	Depth
Direct Vent	DVEL 8	No	8000 Btu/h (2.32 Kw)	18 m ² (194 ft ²)	13 5/8"	20"	7 3/8"
Direct Vent	DVEL 12	Yes	11000 Btu/h (3.20 Kw)	28 m ² (301 ft ²)	17 3/8"	20"	7 5/8"
Direct Vent	DVEL 20	Yes	17000 Btu/h (4.94 Kw)	46 m ² (495 ft ²)	27 3/8"	20"	8 3/8"

ESKABE S.A.

ISO 9001-2015 IRAM-R 9000-365

www.eskabe.com.ar

HEADQUARTERS

Dr. Nicolás Repetto 1545
(C1416CLI) Ciudad Autónoma
de Buenos Aires, Argentina
Tel: (54 11) 4588-4200
Export contact: comex@eskabe.com.ar

INDUSTRIAL PLANTS

Av. Monseñor Zabala (Ruta 2) N° 323
(D7606IFD) Mar del Plata, Argentina

Calle 81 (ex Pilar) N° 1456
(B1650HQF) San Martín, Buenos Aires, Argentina



